



# The Interplay Between Missing Data and Out-of-Order Measurements using Data Fusion in Wireless Sensor Networks

Piyush K. Shukla<sup>1,\*</sup>, Ozen Ozer<sup>2</sup>

<sup>1</sup> Department of Computer Science Engineering, University Institute of Technology, Rajiv Gandhi Proudyogiki Vishwavidyalaya (UIT-RGPV), Bhopal, Madhya Pradesh 462033, India.

<sup>2</sup> Department of Mathematics, Kirklareli University, Kirklareli, 39100, Turkey

Email: [piyush@rgpv.ac.in](mailto:piyush@rgpv.ac.in); [oozenozer@gmail.com](mailto:oozenozer@gmail.com)

ORCID: <https://orcid.org/0000-0002-3715-3882>

\*Corresponding Author: Piyush Kumar Shukla ([piyush@rgpv.ac.in](mailto:piyush@rgpv.ac.in))

## Abstract

Multi-data transmission is the most important processing of target detection with a reduction in delay in the transmission of the data. This may occur in certain technological circumstances, and it happens significantly often in wireless sensor networks—processing such data to keep track of and make predictions about targets of interest might result in errors due to the inherent nature of the data. The Kalman filter and other algorithms with equivalent functionality are most useful for their principal application, estimating the states of dynamic systems. This difficulty of modeling and filtering such delayed states and missing data is dealt with synergistically throughout this proposed work. This is done to ensure that the best possible results are obtained. Filtering methods similar to the optimal Kalman filter are most utilized in fusing measurement data at different levels. This relatively creative technique includes filtering delayed states while also using observations that have been randomly excluded, then putting those screened delayed states and words to use in a process that involves fusing data. One of these applications is the fusion of images. To successful the task of performance evaluation for the integrated plan, the use of numerical simulations is essential. The state delay, as well as the data that is absent at random, are both included in four distinct alternative algorithms. These algorithms are then investigated, and the results are given in this paper. Referring to the gain fusion, the H-infinity a posteriori filter, the H-infinity risk sensitive filter, and the H-infinity risk sensitive filter. To accommodate a scenario that involves MATLAB and the integration of sensor data, global filtering approaches are being updated and evaluated with the use of numerical simulations that are being carried out. In addition, we provide a nonlinear observer based on the gain of the continuous time data fusion filter. Using the Lyapunov energy function, we can conclude on asymptotic convergence in the system. These observers are presented after the previous step. Therefore, the filtering algorithms and the observers described in the current proposed work make a definite step towards improvement for controlling state delays and randomly missing data synergistically for wireless sensor networks.

**Keywords:** Delay; fusion; sensor data; Kalman gain; H-infinity gain; Lyapunov energy.

## 1. Introduction

An ad-hoc wireless network is a dispersed collection of tiny wireless nodes that may dynamically construct and self-organize the network with a temporary topology to form a network that is appropriately designed infrastructure [1]. This kind of network is also known as a wireless mesh network. A mesh network is another name for this particular kind of network. For wireless ad hoc networks, there are two possible configurations: either all of the nodes are within the transmission

range of each other, or just a tiny fraction of the nodes are within the transmission range of each other. In contrast, the rest of the nodes are spread apart.

According to [2], ad-hoc wireless networks may be broken down into two categories: the most straightforward network design and the radio relay topology. Both of these categories can be further subdivided into several subcategories. The kind of coverage range that is present between the nodes is what differentiates these categories from one another. All network nodes should be within the scope of the coverage for the network to have the simplest possible topology. Additionally, the communication method should only need one hop, and there should be no need for routing protocols. The radio relay topology is utilized whenever the network nodes cannot connect directly because they are located outside the coverage area.

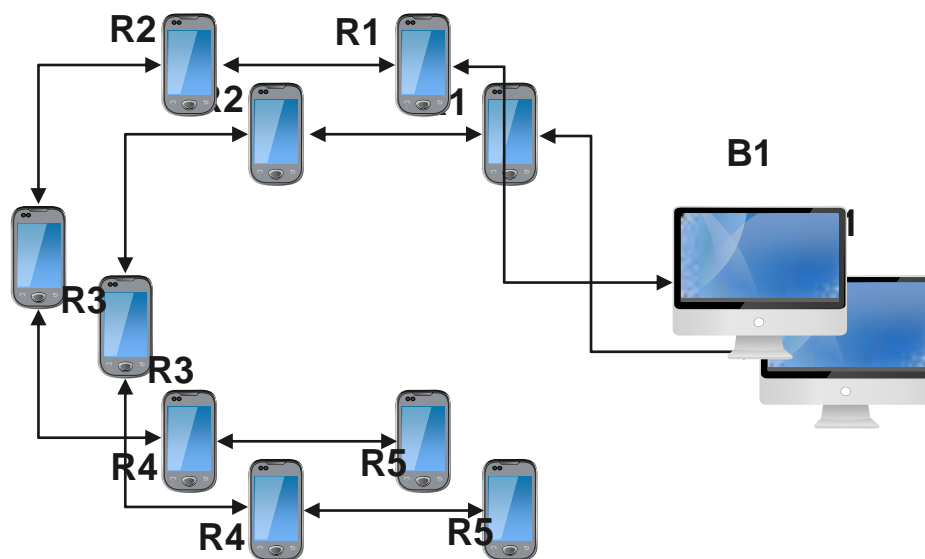

Figure 1: MANET Routing Protocol

In this scenario, communication is carried out with intermediary nodes, each of which works as a router [3] to transmit the message to the next-door neighbor using multi-hop contact. In this scenario, communication is carried out with the assistance of intermediary nodes, each of which works as a router. In this particular scenario, routing algorithms are required to set up the path between the source node and the destination node. The great majority of ad-hoc wireless networks choose multi-hop communication over single-hop communication because it allows for a reduction in the amount of power that is used during the process of data transfer. Because of this network's adaptability, it can continue regularly operating even if the surrounding circumstances deteriorate, a node fails, or there is a shift in the topology of the network's two-tier design.

Utilizing ad-hoc wireless networks has extra benefits, including increased robustness. That is to say, ad-hoc networks can withstand a node's loss, and a node's failure does not affect its performance because they can dynamically rebuild the web with the nodes that have not been lost. Ad-hoc networks [4] also can endure the loss of multiple nodes. Because of the qualities above, applications in dangerous locations are a good fit for using ad-hoc wireless networks. The military, emergency management and operations, catastrophe management, underground coal mining, and large-scale community networks are only a few examples of applications that might benefit from this technology. When constructing ad-hoc wireless networks, one must remember the fundamental difficulties associated with wireless communication. These difficulties include a slow transmission rate, a high bit error rate, noise, a limited coverage area, and worries about the network's safety [5].

The devices that make up the nodes that make up ad-hoc wireless networks are free to roam about anywhere they like since the nodes that make up such networks have minimal resources. Because of this, the communication linkages that connect the nodes are subject to a degree of variability from time to time. This variability is caused by shifts in connectivity that occur among the nodes as a direct consequence of the circumstances in the surrounding environment. The design of protocols [6]

for regular cable networks is significantly more straightforward than the design of protocols for wireless ad hoc networks, which makes the construction of protocols for wireless ad hoc networks much more complicated [7].

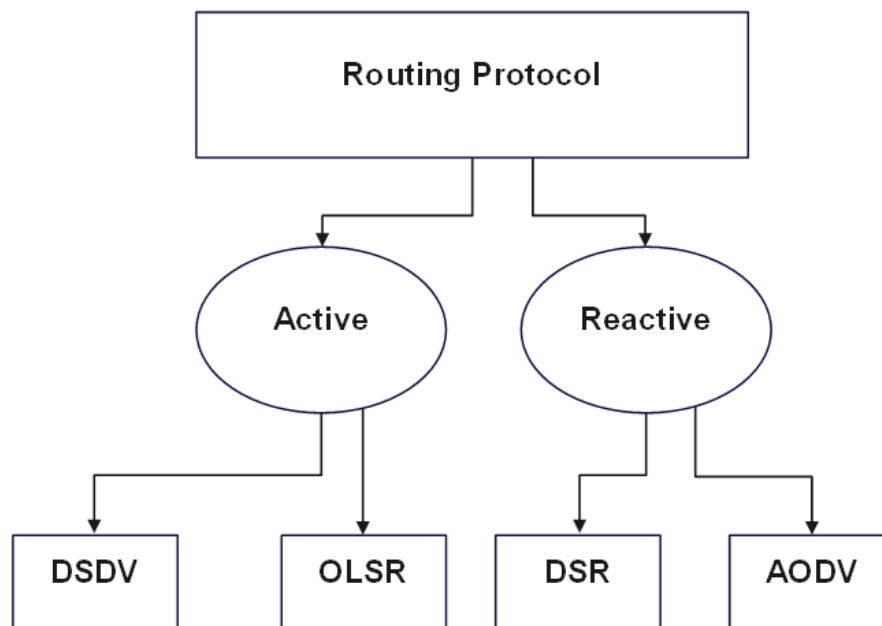

Figure 2: Existing Routing Protocol

Another vital consideration that must not be overlooked is this one. For this reason, it is necessary to modify traditional protocols used in wired networks to design new lightweight protocols for wireless ad hoc networks. These modifications are required because it is impossible to use the same protocols used in wired networks. These new protocols should have a smaller overall footprint, use less energy, and enable reliable, efficient, and secure communication between nodes. In addition, they should have a lower energy consumption. Mobile Ad hoc Networks (also known as MANETs) [8] and Wireless Sensor Networks (also known as WSNs) are two of the most prevalent forms of wireless ad hoc networks that are now in use. Both of these networks are also known by their respective acronyms. Our investigation is centered on WSN as its core area of interest.

Mobile Ad hoc Networks, most often referred to as MANETs, are a particular flavor of the ecosystem concerning wireless networks. It is not the same as traditional wireless networks, constructed on top of existing infrastructure. The network does not need infrastructure and has a dynamic topology, a restricted link bandwidth, and fluctuations in the link, node capabilities, and resource-constrained devices. Additionally, this kind of network has a limited link bandwidth. MANET [9] has recently come to be recognized as a potentially beneficial design paradigm for wireless networks of both the current generation and those to come in the future. It is also capable of auto-configurable wireless networking, in addition to being able to organize and configure itself wirelessly. Due to the simplicity and speed with which they may be set up, MANETs have found their way into a wide range of different kinds of applications. The military, collaborative and distributed computing, disaster assistance, surveillance, sensing, and monitoring are just a few examples of applications that might benefit from this technology.

MANETs are composed of battery-operated devices known as nodes. However, the nodes can lose power if the energy they provide is not used effectively [10]. Nodes need greater intelligence since they are required to fulfill the roles of the transmitter, receiver, and intermediate forwarder. A

dynamic topology [11] produces frequent path breaks, which, in turn, results in the frequent invocation of route discovery and route maintenance methods. As a consequence, an excessive amount of energy is being used, and as a direct consequence, the network's lifetime is drastically reduced. Communication [12] can only occur if a direct route leads from the sender to the receiver. This is because the data packets must travel from one node to the next throughout the network to arrive at their final destination. To identify a multi-hop route between the source node and the destination node, it is necessary to perform an expensive and time-consuming process known as the global flooding of packets over the network.

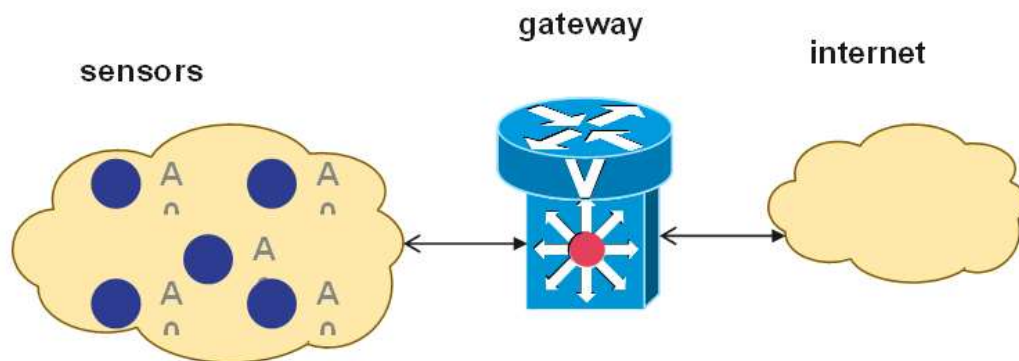

Figure 3: Sensor Gateway in Wireless Sensor Network

When we consider anything costly, we refer to it as having a high degree of resource consumption, particularly regarding the energy and bandwidth it uses. Traditional routing protocols such as the Routing Information Protocol (RIP) and Open Shortest Path First (OSPF) are unsuitable for usage with MANETs. Each node in an ad-hoc network needs to perform the function of a message relay for the other nodes that are part of the same network. Consequently, the quantity of energy used is one of the most significant challenges in ad-hoc wireless networks. The rate of expansion in the sectors of computers and communication cannot be compared to the speed of advancement made in the field of battery technology. This difference is because the batteries' technologies need electrical energy input to work correctly. Therefore, even though developments are being made in the field of battery technology, the protocols of ad hoc wireless networks will continue to work toward lowering the amount of energy used by the networks. The broadcasting operation is one of the most important in MANETs and is often used by routing protocols [13].

The broadcasting process may drain the amount of energy available in the nodes of a WSN if proper precautions are not taken to reduce the frequency with which broadcasting occurs and the number of nodes that are actively engaged in broadcasting. Broadcasting has the potential to rapidly become an activity that requires a significant amount of energy if it is not managed well. A fundamental method for broadcasting without using global information is called Simple Flooding (SF), a methodology in which a broadcasted packet is relayed at least once by every node in the network [14].

Simple Flooding (SF) is a fundamental method for broadcasting without using global information. Because SF requires a more significant amount of energy, the MANET will have a much shorter life. The use of MANETs has significantly aided the expansion and development of WSNs. The method in which wireless sensor networks (WSNs) operate is more comparable to how mobile ad hoc networks (MANETs) use since, except for the base station, wireless sensor networks (WSNs) do not have any infrastructure. The forerunner to the research project that we are now working on is known as WSN, and it is a subtype of MANET.

It has been determined that the following characteristics are significant to WSNs: a) The sensor's capacity to interpret data and maintain communication with other nearby sensors and its

environmental sensing capabilities is of critical importance. b) The primary objective of in-network data aggregation is to get rid of needless packet transmission. This may be accomplished by filtering out redundant sensor data and incremental evaluation of the semantic value of the data. c) Finding one's location is a crucial use of sensor networks, and the difficulty of estimating the amount of time needed to do so is crucial. The new encoder's objective is to provide the most accurate time delay estimate possible within the constraints of a predetermined bandwidth budget. d) Implementing a control network on top of a communication network may result in stochastic delays and packet dropouts, which will unfavorably decrease performance and cause instability. Three e) In the modern world, sensors are used in almost every industry to detect temperature, humidity, and pressure. Depending on the sector, real-time transmission of those measures to the appropriate location in an instant is of the utmost importance.

Typically, using intelligent sensors helps boost operational efficiency and saves money. Measurement data level fusion (MLF) and state vector fusion are the primary ways that data and information from two or even more data types may be combined. a) MLF is for measurement data level, and b) stands for state vector fusion (SVF). [15] It is essential to investigate the issue of missing measurements in the filter cycle and the state delays simultaneously. In the context of multisensory data fusion for target tracking, this joint/combined element has not attracted much attention; nonetheless, considerable work has previously been done in specific exceptional instances.

The technique of multisensory data fusion, also known as MSDF, is very significant for a wide variety of civilian and military applications, including a) target tracking, b) automated target recognition (ATR), and c) wireless sensor networks. The information gathered from various sensors is then combined appropriately so that it may provide a more comprehensive picture of the item's current state. Nevertheless, there is a possibility that a few or many measurements will be lost in the course of a data transmission channel (from one or more sensors). Therefore, it is of the utmost importance to investigate and evaluate the performance of the data processing algorithms in the presence (and despite) of missing measurements (missing data, MD), which means that in the absence of specific signal data at certain times; the random (size) noises that are present for these channels are determined. Additionally, some delays may be current in certain stages of the dynamic system representing a WSN. This is something that needs further investigation. As a result, it is essential to think about the algorithms for processing and filtering data in a complementary fashion. In the current proposed work, both the state delay and the randomly missing measurement data in filtering algorithms and the measurement data level fusion are treated synergistically. This is done in conjunction with the fusion of measurement data. The data may be absent for one of two reasons: I there was an issue with one of the sensors; or ii) there was an issue with one of the communication channels; in this case, the data that was received may merely be noise, and the signal could be absent. As a result, it is of the utmost importance to deal with the scenario of missing data in a filter in a manner that is both optimum and formal. As a result of the latency time that particular channels have, many real-time systems can potentially have temporal delays. The stability and performance of the system as a whole are affected by time delay.

## 2. Related Work

The process of multisensory data fusion, which is also known as MSDF, is essential for a wide variety of applications, some of the most notable of which are a) target tracking, b) automated target recognition (ATR), and c) wireless sensor networks. a) Target Tracking Automated Target Recognition (ATR) these applications may be found in both the civilian and the military sectors at the same time. Because it is necessary to collect information from various sources to determine the condition and identification of the item being investigated and observed, the measurements are accessible from more than one sensor. The goal is to determine the condition and title of the thing being investigated and monitored. This is because the primary objectives are establishing the item's identity and determining its current state. After the information has been gathered from several sensors, it is combined appropriately to offer a more comprehensive picture of the item's current condition [16]. This is done after the information has been obtained. Along the path of a data transmission channel, there is a possibility that a few or many measurements may be lost at varying times. This might happen at any point (from one or more sensors).

This is because the omission of specific signal data at particular periods might considerably affect the correctness of the findings. This is because reconstructing the original signal becomes a highly challenging task when there is insufficient data. This takes place during the process of fusing several levels of data. In the SVF, the data sets collected from each sensor are first put through an analysis

performed by KFs independent of one another. After that, a well-known formula for the SVF is used, and all of these separate, individual assessments of the condition are added together to provide the final result [17]. In other words, the weights are based on the information used to process the original signal-data sets. Put another way, the consequences are determined by the data used during the initial signal-data processing stages. To put it another way, the information utilized while processing the original signal-data sets determines the weights applied to the various signals. If any measurements are overlooked while KF is processing the data, the quality of the filter's performance will not be as high as it otherwise would have been in the absence of this oversight.

As a direct result of this, it is of the utmost need to investigate the issue of missing measurements across the whole of the filter processing cycle, in conjunction with the delays in the state. In the context of multisensory data fusion for target tracking, this joint or combined element has not gotten much attention; despite this, substantial work has been done in rare circumstances [18], [19]. These are the three different kinds of data loss that might take place during online monitoring. In [20], an investigation is made into a system known to have many sensor delays, even though the algorithm seems to have a lot of variable parts.

The work in [21] contains a conversation on missing data and outliers in statistical analysis. However, the illustration in [22] may only be used in contexts that include time series that are not too intricate. Only the missing observations are discussed in the references [23], but the topic of state delay is mainly ignored. In [24], the only issue of latency inside the system is considered. When developing filtering algorithms in a way that is synergistic and when fusing measurement data at various levels, it is essential to take into consideration the state delay as well as any routinely missing measurement data. This is because it is necessary to consider any missing measurement data. If there are gaps in the data, it might be for one of these two reasons: a) a sensor could be malfunctioning, or b) there could be an issue with the communication connection. In this circumstance, the data received may only consist of noise, but the signal may not have been received at all due to the possibility that it was not received. As a direct result of this, it is of the utmost importance to handle the problem of missing data in KF in a well-organized and effective way. Due to the latency time connected with specific channels, many real-time systems have delays over time. These delays are caused by the passage of time. One of the variables that significantly adds to the overall instability and performance of the system is the duration of the time delay that users are experiencing. Additionally, there is a possibility that it will lose track of what it is monitoring. In addition, there is a chance that it will get confused about the thing it is trying to keep an eye on. We provide several methods based on KF [25] and evaluate how well they function in various measurement-level data fusion situations. These algorithms are used to merge data on a variety of levels. In instances like this, some measurement data are missing randomly; consequently, they cannot be utilized for further processing within the filters. This is because the missing data cannot be reliably predicted. In addition to this, some illnesses have a state that is delayed.

### 3. Proposed Work

It is the worldwide process of collecting and directing data through multi-node data transmission and routing systems, handling information in the middle of the road hubs to lessen asset utilization (specific energy), thereby increasing system lifetime. In other words, it is the process of data center consolidation. Consolidation of data centers is the name given to this procedure. There are two distinct methods available for computing the total amount included inside the system; one of these methods requires size reduction, while the other does not. The method of linking and compressing the information bundles received by a hub from its neighbors is referred to as "in-system total with size lowering." It is described by the phrase "in-system total with size lowering." This is done to cut down on the overall length of the package that will be delivered or transported toward the sink. When referring to integrating information packets from several neighbors into a single information parcel, the phrase "in-system total without size reduction" is used. This is done before preparing the information estimate in Eqn 1, which is why the term "in-system total without size reduction" is used.

$$\text{one} [x(k+1) \ x(k)] = [\phi \ \phi \ I \ 0] [x(k) \ x(k-1)] + G[w(k) \ 0] \quad (1)$$

$$[x(k) \ x(k-1)] = x_i; [\phi \ \phi \ I \ 0] = \phi; [x(k+1) \ x(k)] = x_{i+1}; [u(k) \ 0] = w_k \quad (2)$$

With the above equivalence, we rewrite (1) as

$$x_{i+1} = \phi x_i + C w_i \quad (3)$$

The measurement equation is given as

$$z_{i+1} = H[x(k + 1) x(k) ] + v_{i+1} \quad (4)$$

$$z_{i+1} - Hx_{i+1} + v_{\lambda+1} \quad (5)$$

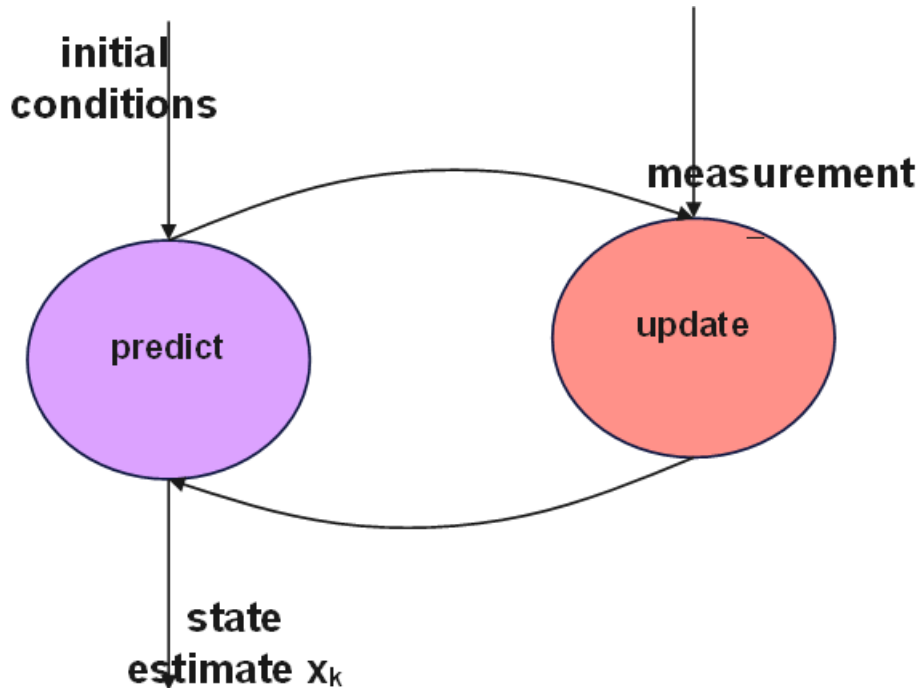

Figure 4: Filter Statement with Processing Unit

Let  $z_{k+1}$  stand in for the state estimate at time  $k+1$ , while  $x$  I will stand in for the updated or posterior estimate at time  $k$ . Both of these estimates will be filtered (after the measurement data are integrated). After then, the amount of time needed for the state estimate to become widespread across the system is

$$x^-_{i+1} - \phi x^{\wedge}_i \quad (6)$$

The measurement prediction is given by,

$$z^-_{x+1} - H_{s+1} \quad (7)$$

As a result of the fact that equations (1) through (3) are equivalent to one another, the fitting equations for model 1 of the delayed state are the same as those for the conventional KF model. This is easily discernible because the equivalence in those equations makes the relationship between them very clear (covariance propagation).

$$P^-_{i+1} = \phi P^*_i \phi^T + G Q G^T \quad (8)$$

$$\text{(Kalman gain)} K = P^-_{i+1} H^T (H P^-_{E+1} H^T + R)^{-1} \quad (9)$$

(Measurement update)

$$x^{\wedge}_{i+1} = x^-_{i+1} + K(z_{i+1} - \xi_{i+1}) \quad (11)$$

(Covariance update)

$$\hat{P}_{i+1}^- = (I - KH)P_{i+1}^- (I - KH)^T + KRK^T \quad (12)$$

As a result, the state delay is accounted for in Model 1 via the use of a composite method. The delayed state may be represented using this model 2, which accommodates it as

$$x_{k+1} = \phi x_k + \phi x_{i-1} + Cw_1 \quad (13)$$

$$z_{k+1} = Hx_{k+1} + v_{k+1} \quad (14)$$

$$x_{i+1}^- = \phi_i x_i^- + \phi x_{i-1}^- \quad (15)$$

$$z_{i+1} = Hx_{s+1}^- \quad (16)$$

In this model 2 of the delayed state, the KF equations are presented as follows, which can be found by comparing equations (2), (6), and (10).

$$\vec{P}_{R+1} = \phi_1 P_k \phi_0^T + \phi P_{1-1}^T \phi_1^T + GQG^T \quad (17)$$

(Kalman gain)

$$K = P_{s+1}^- H^T (HP_{s+1}^- H^T + R)^{-1} \quad (18)$$

(Measurement update)

$$\hat{x}_{i+1} = x_{\lambda+1}^- + K(z_{k+1} - Hx_{\lambda+1}^-) \quad (19)$$

$$P_{\varepsilon+1}^- = (I - KH)P_{\lambda+1}^- (I - KH)^T + KRK^T \quad (20)$$

### 3.1 Combined Filtering Algorithm for the Delayed States and Missing Measurement Data

$$x_{i+1} = \phi x_i + \phi x_{i-1} + Cu_i \quad (21)$$

The measurement equation is given as

$$z_{l+1} = \gamma(k+1)\mu_{k+1} + v_{i+1} \quad (22)$$

$$E\{\gamma(k) = 1\} = \beta(k) \text{ And } E\{\gamma(k) = 0\} = 1 - \beta(k) \quad (23)$$

It is presumed that the constant's value has already been provided at an earlier time. This is a presentation of the KF-like filtering approach, which, in addition to being able to manage and incorporate missing data, can also take into account the delayed state:

$$x_{i+1}^- = \phi x_i^- + \phi x_{i-1}^- \quad (24)$$

$$P_{x+1} = \phi P_x F_0^T + \phi P_{i-1}^N F_1^N + GQG^T \quad (25)$$

$$K = \beta P_{s+1}^- H^T (\beta^2 HP_{s+1}^- H^T + R)^{-1} \quad (26)$$

$$\hat{x}_{i+1} = x_{i+1}^- + K(z_{i+1} - \beta H x_{i+1}^-) \quad (27)$$

$$P_{i+1}^- = (I - \beta KH)P_{i+1}^- (I - \beta KH)^T + KRK^T \quad (28)$$

This filter, along with its many versions, was analyzed in [2] for randomly missing data, but there was no state delay in the analysis.

### 3.2 Filter Composed of Two Components for Fusing State Vectors with the Delayed States

In this scenario, the impacts of combining the delayed state model 1 with the measurement data level fusion are looked at and considered. Both equations (29 and 30) may be seen as equivalent representations of the state model (31). The models of the measurements that were obtained by the two sensors are shown as

$$z_{u+1} = H_1[x(k+1) \ x(k)] + v_{2k+1} \quad z_{u+1} = H_2[x(k+1) \ x(k)] + v_{1k-1} \quad z_{2+1} = H_1x_{i+1} + v_{ik-1} \quad z_{2+1} = H_2x_{i+1} + v_{2k+1} \quad (29)$$

It is clear that the state model is the same as that which is represented in equations (30) and (31), and equations (32) and (33) explain how the time propagation portions of the filter work (2.6). Because there are two channels of measurement data, also known as two sensors, that can be accessed, the equations that describe the measurement data update component of the filters that are shown below have been made necessary.

(Measurement update)

$$\hat{x}_{i+1} = (I - K_2H_1 - K_2H_2)x_{i+1}^- + K_2z_{1+1} + K_1z_{2+1} \quad (30)$$

(Covariance update)

$$P_{i+1}^- = (I - K_2H_1 - K_1H_2)P_{i+1}^-(I - K_1H_1 - K_3H_2)^T + K_2R_1K_2^T + K_3R_2K_3^T \quad (31)$$

#### 4. Experimental Results and Analysis

The reader's performance is validated by carrying out numerical simulations in MATLAB. These simulations verify the effectiveness of the filters that are being provided. Every sample is collected at one-second intervals, and the simulations are conducted for a total of two minutes and ten seconds. These equations are used to construct the data. This is done to simulate the effects of combining data from two sensors. Even if position measurements are the only ones used for filtering, the location, velocity, and acceleration of a moving object are all included in the state vector  $x$  of the object. This is because the vector represents the item's state as it moves. It was chosen to utilize the system's state model 1 with the state transition matrices as the criterion for the evaluation.

$$\phi_0 = [1 \ T \ T^2/2 \ 0 \ 1 \ T \ 0 \ 0 \ 1]; \quad \phi = x [1 \ T \ T^2/2 \ 0 \ 1 \ T \ 0 \ 0 \ 1] \quad (32)$$

In state delay model 2, the same matrices are used, but they are processed using a different method than what was covered in the previous section. Additionally, a small constant governs how the delayed state affects the system. This model is similar to state delay model 1 but more complex. The following is a textual representation of both the measurement model and the process noise coefficient matrix:

$$G = [T^3/6 \ T^2/2 \ T]; \quad H = [1 \ 0 \ 0] \quad (33)$$

The simulation and the filter use well-chosen initial conditions to depict the states they are trying to represent accurately. The fact that these measures have numerical values that are relatively low gives the impression that the filter has a performance that is, on the whole, good. In addition to this, the evidence may be seen in the performance graphs.

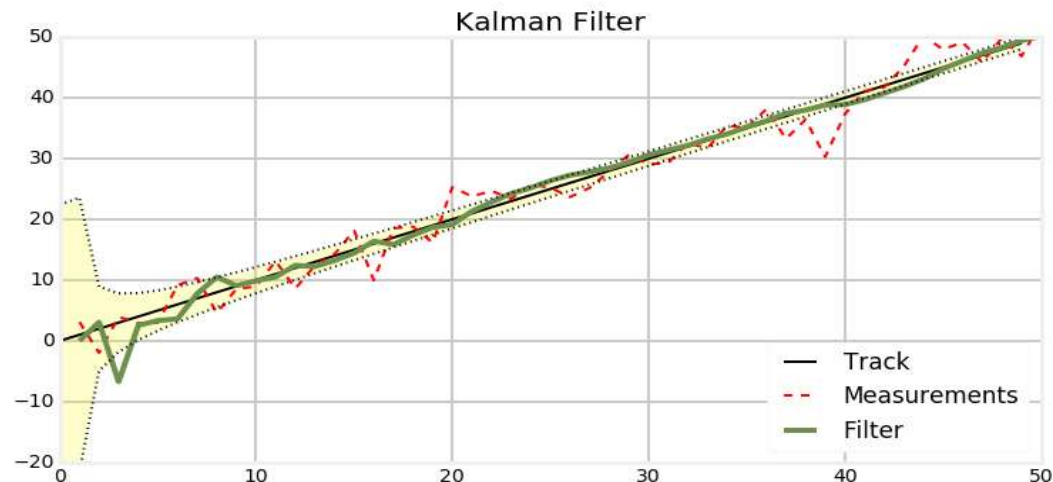

Figure 5: illustrates the actual filter performance, which includes all three states and the residuals from the DS2 filter.

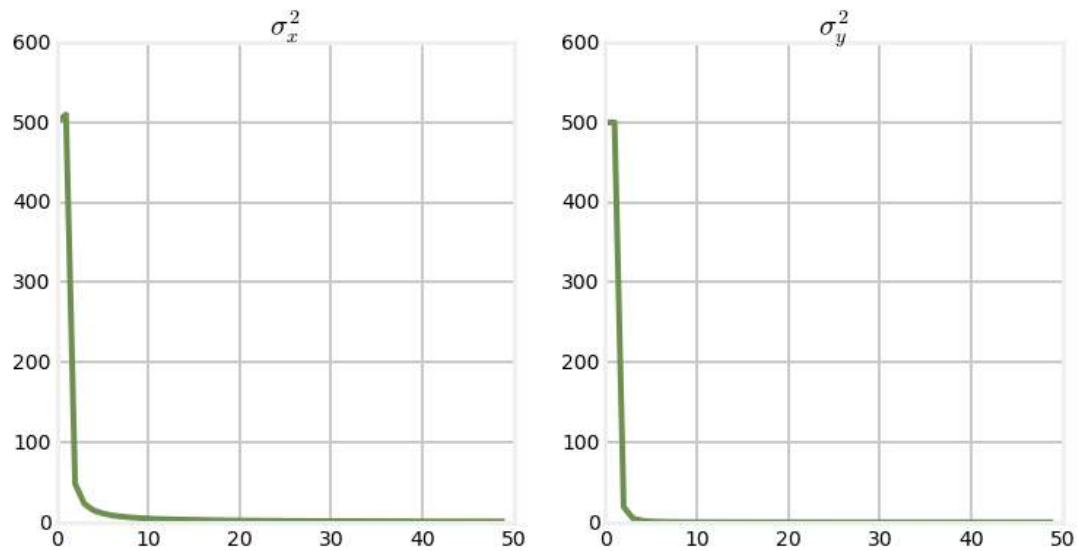

Figure 6: State Error in the Filtering Technique

Figure 6 depicts the state errors in addition to the position measurement autocorrelations (ACR), both of which have limitations that were determined using the same filter making use of a delayed state DS2.

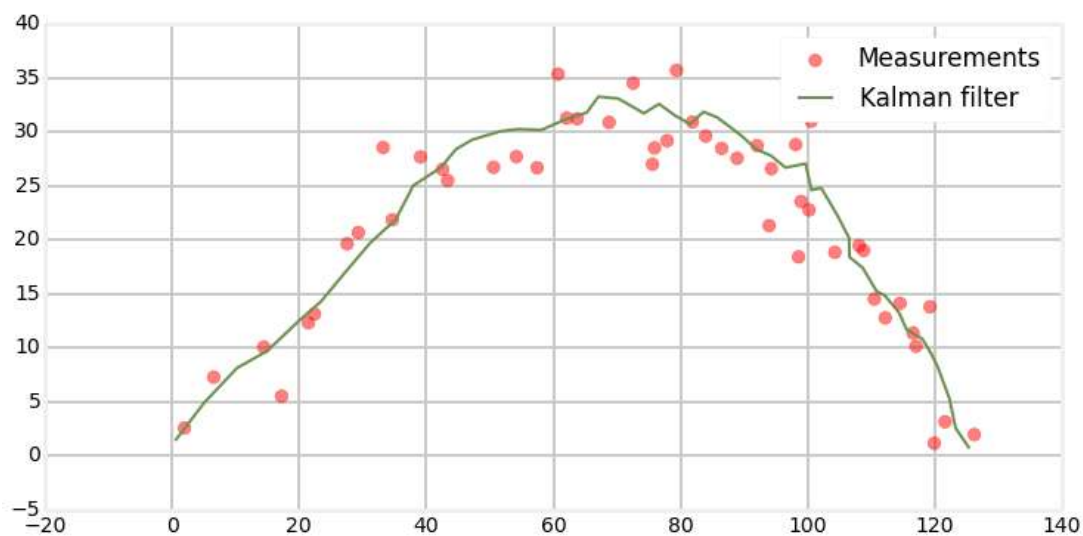

Figure 7: Position Measurement Autocorrelations

Figure 7 illustrates that a lower threshold number will lead to a more significant quantity of data being missed than the case with the current setting.

In this specific example, to demonstrate how the algorithms function, an ad hoc approach has been used as the method of choice. After considering all that has been said, it is pretty evident that the performance of the filters is enough. This is because it has been discovered that each of these components is inside the confines of their respective theoretical categories, which explains why this is the case.

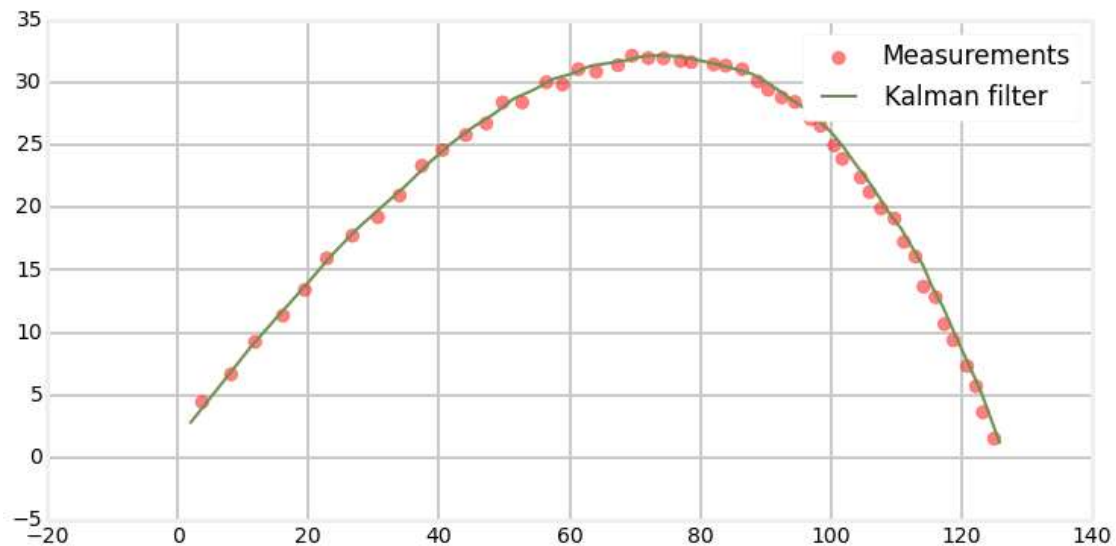

Figure 8: Kalman Filter measuring unit

Figure 8 displays the state faults together with their respective borders. These faults originate from a filter that has a delayed state DS2F, two sensors, and does not have any missing data are shown in Figure 9. These measurements were obtained by combining the outputs of two sensors. The thresholds applied for sensor 1 were set at 0.5, while the thresholds for sensor 2 were set at 0.95. Figure 8 is an illustration of the state errors along with their bounds. These mistakes result from the DS2MF filter having a delayed state and the data level fusion employing two sensors and missing data thresholds of 0.5 and 0.95, respectively. Figure 9 illustrates the position measurements as well as the residuals that were produced by the filter that was used.

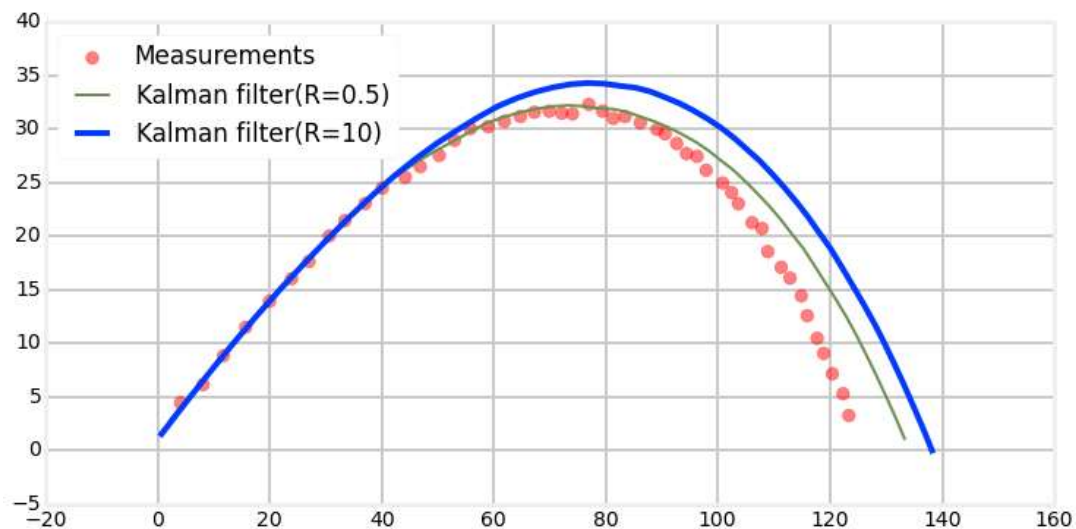

Figure 9: Kalman Gain with Infinity Gain

The criteria for missing data for sensor 1 are set at 0.95, while the thresholds for sensor 2 are set at 0.5. Figure 9 illustrates the state errors and their borders for the filter with delayed state DS2MF, missing data, and data level fusion. It has been observed that all of these filters do an excellent job of managing the delayed states and missing data in the measurement level fusion. This is a result of the fact that it has been shown that several mistakes fall within the bounds of their respective theoretical frameworks.

The performance of the matching filter continues to be excellent and acceptable even though the number of mistakes will rise as more data is lost; The assertions that have been stated in this paragraph are supported by the information that is shown in Figures 3 through 8.

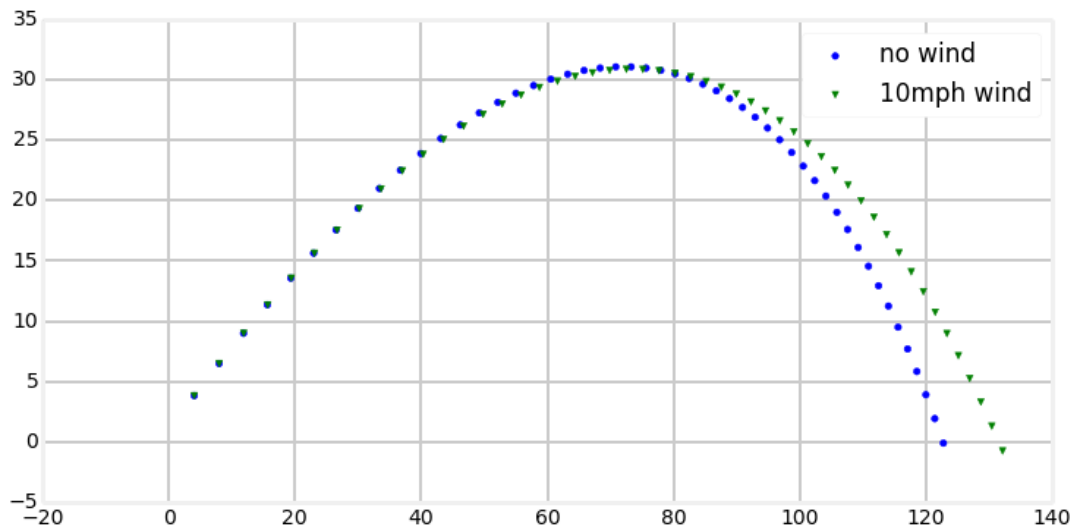

Figure 10: Sensor Data in Kalman Filter

Consequently, the KF-type filters for delayed states and/or missing data, as well as for measurement level fusion, have been generated synergistically and confirmed utilizing numerically simulated data. This was accomplished in order to meet the requirements of measurement-level fusion. Fusion of measurement levels is possible with the help of these filters. The values of the measures have been seen to decline gradually when more data, particularly of them, are not present. This phenomenon has been observed. Even if additional measurement data are absent, it has been assured that the performance of the suitable filters with either one or two sensors will be highly gratifying. This is true even if additional measurements are missing from the dataset. Consequently, taking everything into account, we are in a position to assert that the performance of these filters has been neither inadequate nor unacceptable.

## 5. Conclusion

Fusion of measurement levels is possible with the help of these filters. The values of the metrics have been seen to worsen when further data are absent steadily. This phenomenon has been observed. However, this drop is not even close to being significant. Even if there are missing additional measurement data, it has been assured that the performance of the suitable filters with either one sensor or two sensors will be highly gratifying. This is true even if additional measurements are missing from the dataset. As a direct result of this, it has been shown that the overall performance of these filters is both excellent and acceptable. In order to integrate the system state delay into the dynamic model and randomly missing data into the measurement equation, the appropriate adjustments to four different filtering-cum-fusion algorithms have been described. These adjustments were necessary in order to accomplish the goals above. The disclosure of the procedures allowed for the execution of these alterations to be carried out. This study offers a novel interpretation in the form of a cross-utilization of observer theoretic analysis in predicting the stability of the global data fusion technique. Research of this kind might be put to use in the development of observers and data fusion algorithms for use in communications systems, wireless sensor networks, mechanical and aeronautical engineering (target tracking), and robotics.

**Funding:** This research received no external funding.

**Conflicts of Interest:** The authors declare no conflict of interest.

## References

- [1] Aid, J.P., Humax and Knightly, K.W. "Impact of denial-of-service attacks on Adhoc networks" IEEE/ACM Trans. Net., Vol.16, No.4, pp.791-802, 2008.
- [2] Abbas, S., Meranti, M. and Llewellyn-Jones, D. "Signal Strength Based Sybil Attack Detection in Wireless Ad Hoc Networks" in Proc. IEEE. Developments of e-system Engineering., pp. 192-195, 2009.

- [3] Akyildiz, I.F., Weilian, Su., Sankarasubramaniam, Y. and Cayirci, E. "A survey on sensor networks" IEEE Trans. Comm. Vol.40, No.8, pp.102 -144, 2002.
- [4] Amitabh Mishra, Ketan Nadkarni, and Animesh Patcha, "Intrusion detection in wireless Adhoc networks" IEEE Trans. Wireless Comm., Vol.11, No.1, pp.48 - 60, 2004.
- [5] Arafat, J. and Dweik, A.L. "Exact performance analysis of synchronous FH-MFSK wireless networks" IEEE Trans. Comm., Vol.58, No.7, pp.3771-3776, 2009.
- [6] Binwei Deng, Wen Li, Guangming Huang, Shouyin Liu, and Qin Zhang, "High-accuracy and low-cost localization scheme for wireless sensor networks", J. Electronics, Vol.99, pp.455-476, 2012.
- [7] Bhalaji, N. and Shanmugam, A. "Reliable routing against selective packet drop attack in DSR based MANET", J. Software, Vol.4, No.6, pp.536-543 2009.
- [8] Brown, J. and Xiaojiang, Du, "Detection of selective forward attacks in heterogeneous sensor networks" in Proc. IEEE Comm., pp.1583-1587, 2008. 9.
- [9] Bojkovic, Z. and Bakmaz, Z. "A Survey on sensor network deployment" WSEAS Trans. Comm., Vol.7, No.12, pp.28-466, 2008.
- [10] Ngai, C.H., Jiangchuann, L. and Michael, R. "On the Intruder detection for sinkhole attack in wireless sensor networks" in Proc. IEEE ICC, 2006.
- [11] Nait-Abdesselam, F. "Detecting and Avoiding wormhole attack in wireless Adhoc networks" IEEE Trans. Comm., Vol.46, No.4, pp.127-133, 2008.
- [12] Newsome, J., Shi, E. and Song, D. "The Sybil attack in sensor network: analysis & defenses" in Proc. IPSN, ACN Press, USA, pp.259-268, 2004.
- [13] Papdimitriou, A., Fessant, F.L., Viana, A.C. and Sengul, C. "Cryptographic protocols to fight sinkhole attacks on tree-based routing in wireless sensor networks" in Proc. NPSEC, 2009.
- [14] Perrig, A., Szewczyk, R., Wen, V., Culler, D. and Tygar, J.D. "SPINS: security protocols for sensor networks" ACM Trans. Wireless Net. Vol.8, No.5, pp.521-523, 2002.
- [15] Pursley, Michael, B. Introduction to digital communications. Upper Saddle River, Pearson Prentice Hall, 2005.
- [16] Qinghua, Z., Pan, W., Douglas, S. and Ning, P. "Defending against Sybil attacks in sensor networks" in Proc. Distributed Computing Systems, pp.185-191, 2005.
- [17] Qiu Hui-Min, "Principle of Sybil attack and the defense", J. Net. and Computer Security, Vol 10, pp.63-65, 2005.
- [18] Rajasegarar, S., Leckie, C. and Panaiswami, M. "Anomaly detection in wireless sensor networks" IEEE Trans. Wireless Comm., Vol.15, No.4, pp.34-40, 2008.
- [19] Ramakrishnan, M. and Shanmugavel, S. "New Approaches to Routing techniques of MANET node for optimal network performance", J. Computer Science and Net. Security, Vol.8, No.11, pp. 369-376, 2008.
- [20] Ryu H.G. "Performance of DS/SFHSSMA system with overlapping BFSK in the presence of both MTJ and MAI" IEEE Trans. Veh. Tech., Vol.52, pp.267-273, 2003.
- [21] Sabbah, E. and Kang, K.D. "Security in wireless sensor networks", in Guide to wireless sensor network Springer-Verlag, London, pp.491-512, 2009.
- [22] Satyajayant Misra and Sowmya Myneni, "On identifying power control performing Sybil nodes in wireless sensor networks using RSSI" in Proc. IEEE Globecom, pp.1-5, 2010.
- [23] Shaohe, L., Xiaodong, W.F., Xin, Z. and Xingming, Z. "Detecting the Sybil attack cooperatively in wireless sensor networks" in Proc. Computational Intelligence and Security, pp.442-446, 2008.
- [24] Shila, D.M., Cheng, Y.U. and Anjali, T. "Mitigating selective forward attacks with a channel-aware approach in WMNS" IEEE Trans. Wireless Comm., Vol.9, No.5, pp.1661-1675, 2010.
- [25] Shi, E., and Perrig, A. "Designing secure sensor networks", IEEE Wireless Comm., Vol.11, No.6, pp.38-48, 2006.